

more information at:



control and versatility

The RTC®5 **control board** provides synchronous, interference-resistant control of scan systems, lasers and peripheral equipment in real time. It is available as a PC interface board, as a PCI-Express board or as a PC/104-Plus module.

A high-performance signal processor and the supplied DLL simplify programming under Windows. Software commands are loaded into the RTC®5's freely-configurable list buffer and processed by the DSP. Every 10 µs, appropriate signals are output to or read-out from the scan system, laser and peripheral equipment.

The RTC®5 communicates with scan systems via the new SL2-100 data transfer protocol. This protocol supports 20-bit control signals and thereby a 16x higher positioning resolution compared to the RTC®4 predecessor board. The RTC®5's processor automatically performs micro-vectorization and image field correction.

For laser control, various programmable laser signals are available for vector and bitmap processing. During execution, the board can provide automatic position/speed/vector-dependent readjustment of laser power.

For SCANLAB scan systems with fully digital servo electronics (e.g. intelliSCAN®, intellcube®, intelliDRILL®, intelliWELD®, powerSCAN i), the RTC®5 also supports all possibilities arising from the iDRIVE® technology. This includes real-time monitoring and remote diagnosis of key operational parameters, simulation-assisted process optimization and the use of different dynamics tunings. The feedback of the scan-system speed can be used for speed-dependent laser control.

Numerous options provide the extensive flexibility system integrators need for meeting diverse customer requirements.

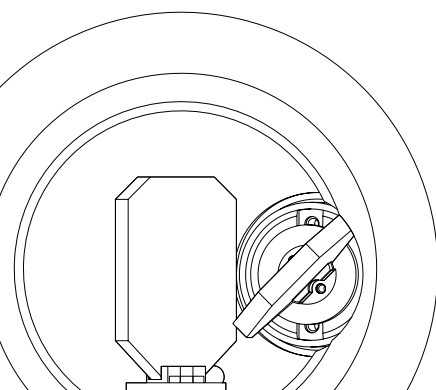

System integration

- PCI bus interface, PCI-Express interface (PCIe-x1 version 1.0) or PC/104-Plus interface
- Any number of RTC®5 PCI or PCIe boards in one PC (up to four PC/104-Plus modules in a stack)
- Master/slave synchronization
- Drivers for (32-bit and 64-bit) Windows 7/Vista/XP/2000 (and Windows XPEmbedded for RTC®5 PC/104-Plus)
- Multi threading, multi processing

Scan system control

- SL2-100 transfer protocol (control of scan systems per XY2-100 transfer protocol via an optional converter)
- 20-bit positioning resolution
- Virtual processing field (24 bit)
- 10 µs output period
- Galvanically isolated signals
- Tuning selection
- Vector and jump mode, tuning auto-switching
- Scan-system diagnosis
- Reading back actual-position values

Laser control

- 15-pin D-Sub connector
- Laser signals with 15 ns resolution and 20 mA output current
- Various laser modes for controlling all typical lasers
- Bitmap mode with pixel frequencies up to 300 kHz, 15 ns resolution, 0-100% laser pulse width
- RS232 interface
- Speed- and position-dependent laser control

Control of peripheral equipment

- 16-bit digital output and input
- 8-bit digital output
- 2-bit digital output and input
- 12-bit analog output (0...10 V)
- McBSP interface
- Stepper motor signals

Command management

- Configurable list buffers with 1,000,000 list positions, protected memory area definable
- Lists and subroutines
- "Short" list commands for changing (laser) output signals without interrupting polygonal traversal (the laser remains on)

- Download verification
- Enhanced list and list execution status
- Definable and selectable character sets
- Marking of dates, times and serial numbers
- Marking of circles and ellipses
- Sky writing
- Conditioning of all list commands possible

Options

- Control of 3-axis scan systems
- Processing-on-the-fly functionality for objects in motion (two encoder inputs with 32-bit counter, up to 8 objects between trigger and marking position, etc.)
- Dual-head capability for simultaneous control of two scan systems
- Customer-specific extensions possible

Still available

- RTC®3 / RTC®4 PC interface boards
- RTC® SCANalone board

Accessories

- **laserDESK**
laser processing software

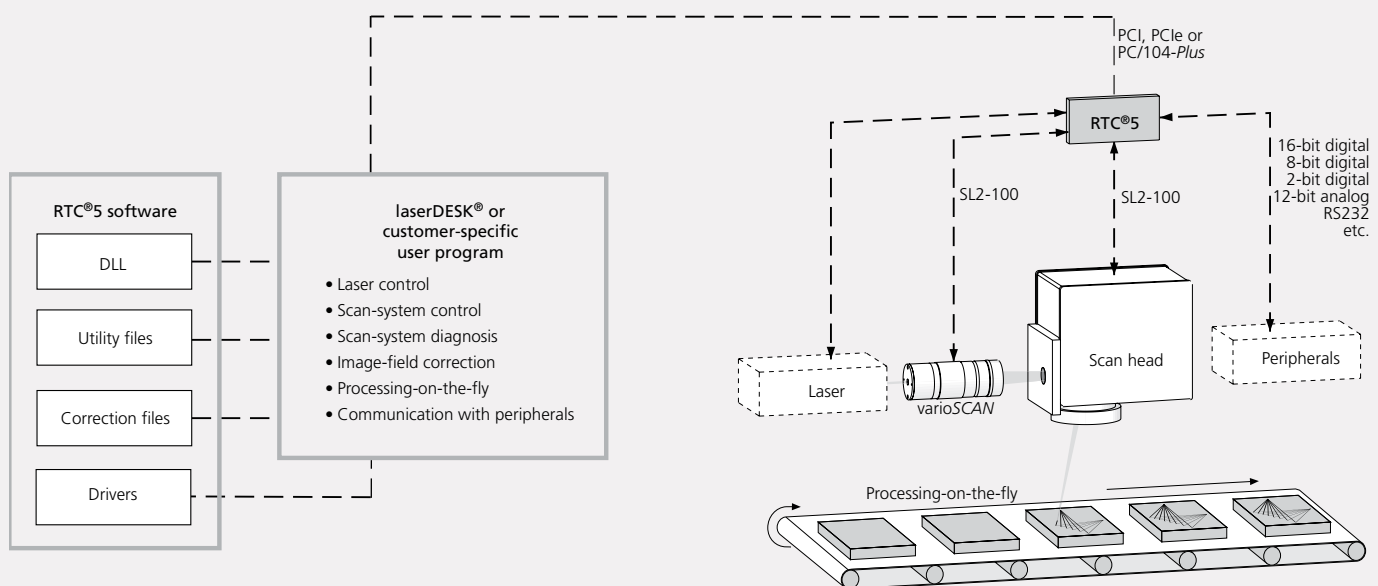

12/2011 Information is subject to change without notice.