



more information at:



## scanning in pocket size

The ultra-compact **scan heads** of the **SCANcube<sup>®</sup>** series deliver excellent dynamics and superior **SCANLAB** product quality in a minimum-size package. The scan heads of the **intellicube<sup>®</sup>** series advantageously combine the features of the successful **SCANcube<sup>®</sup>** and **intelliSCAN<sup>®</sup>** platforms.

Sealed against water and dust, the **SCANcube<sup>®</sup>**'s and **intellicube<sup>®</sup>**'s robust and exceptionally compact housing facilitates straightforward integration into production environments – even confined, difficult-to-access locations. A wide variety of objectives can be used with these scan heads.

**SCANcube<sup>®</sup>** and **intellicube<sup>®</sup>** scan heads bring success to applications demanding very fast marking speeds and integration in the tightest of spaces. Applications include packaging-industry coding and marking of electronic components, i.e. market domains typically served in the past by inkjet systems.

The **intellicube<sup>®</sup>** is also ideal for applications requiring very high dynamics or the acquisition of important status information.

### Typical applications:

- Marking and coding
- Semiconductor and electronics industry
- Processing-on-the-fly

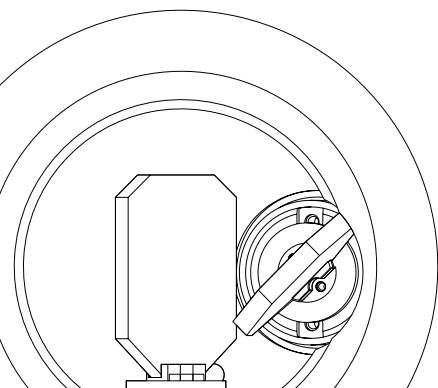

# SCANcube® 7, 8.5, 10, 14

**SCANcube® 7**

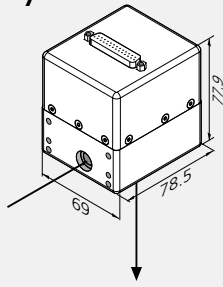

**Beam entrance side**

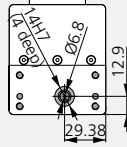

**Beam exit side with**

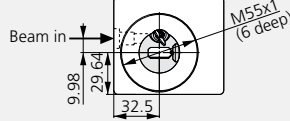

**SCANcube® 8.5**

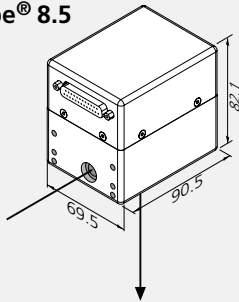

**Beam entrance side**

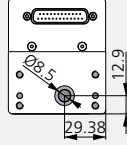

**Beam exit side**

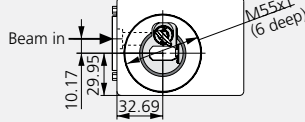

**SCANcube® 10**

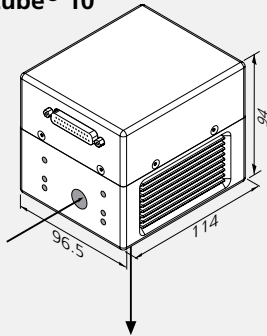

**Beam entrance side**

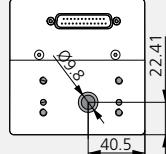

**Beam exit side**

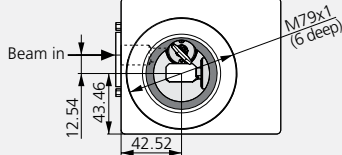

**SCANcube® 14**

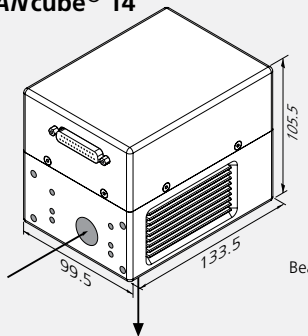

**Beam entrance side**

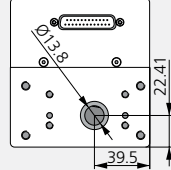

**Beam exit side**

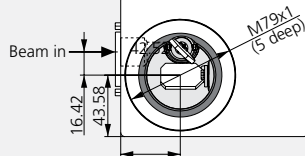

**Legend**

- 1 Beam in
- 2 Connector
- 3 Beam out

all dimensions in mm

Dimensions	SCANcube®			
<b>Aperture</b>	7 mm	8,5 mm	10 mm	14 mm
<b>Beam displacement</b>	9.98 mm	10.17 mm	12.54 mm	16.42 mm

**Optics**

SCANLAB precisely optimizes and tunes all optical components to one another to ensure maximum focus quality and stable process parameters. Optical components offered by SCANLAB include compact objectives, as well as objective mounts for standard objectives. Optics for various wavelengths, power densities, focal lengths and image fields are available.

**Control**

SCANcube® scan heads are equipped with either an analog or a digital standard interface accessible via a 25-pin D-SUB connector.

They are easily controlled via SCANLAB's RTC® PC interface board or the PC-independent RTC® SCANalone board from SCANLAB.

intelicube® scan heads are equipped with a digital standard interface. They are easily controlled via SCANLAB's RTC®4 or RTC®5 PC interface board. Scan head diagnosis and all essential configuration parameters are controlled via software commands.

**Options**

- For optical process monitoring, SCANLAB offers a camera adapter.

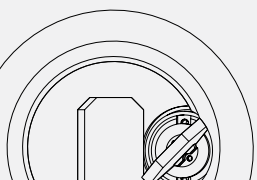

**SCANcube® or intellicube®?**

The intellicube® and SCANcube® are electrically and mechanically inter-compatible.

In addition to the 10 and 14 mm apertures, the SCANcube® series also offers extremely compact scan heads with 7 or 8.5 mm apertures. Further the SCANcube® can be equipped with either a digital or an analog interface.

The intellicube® provides improved dynamic performance. And as a direct beneficiary of SCANLAB's years of experience developing digitally controlled intelliSCAN® scan systems, the intellicube® also offers all the advantages of iDRIVE® technology: high flexibility, superior dynamics, real-time monitoring of actual position and advanced status information, etc.

intellicube® scan heads are available with vector-tuning or step-tuning.

**Quality**

The high quality of SCANLAB's scan solutions is the result of years of experience in the development and manufacture of galvanometer scanners and scan systems. In addition, every scan system must first pass the SCANcheck burn-in test before it is released for shipment to the customer.

**intellicube® 10**

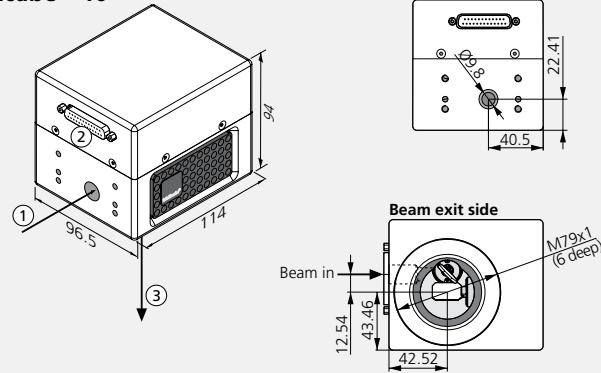

**intellicube® 14**

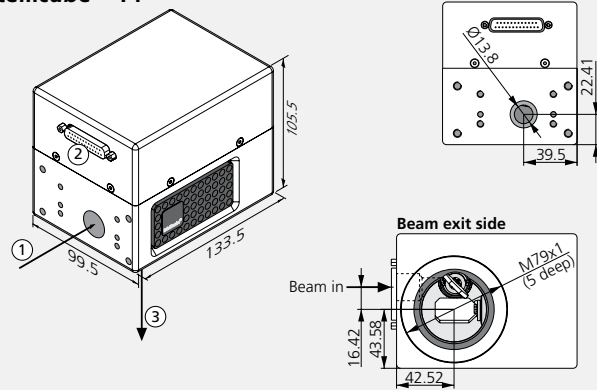

**Legend**

- 1 Beam in
- 2 Connector
- 3 Beam out

all dimensions in mm

The housing dimensions of intellicube® 10 and 14 are identical to SCANcube® 10 and 14.

Dimensions	intellicube®	
<b>Aperture</b>	10 mm	14 mm
<b>Beam displacement</b>	12.54 mm	16.42 mm

## Type-Dependent Specifications

(all angles are in optical degrees)

	SCANcube <sup>®</sup> 7	SCANcube <sup>®</sup> 8.5	SCANcube <sup>®</sup> 10	intellicube <sup>®</sup> 10	SCANcube <sup>®</sup> 14	intellicube <sup>®</sup> 14
<b>Aperture</b>	7 mm	8.5 mm	10 mm	10 mm	14 mm	14 mm
<b>Beam displacement</b>	9.98 mm	10.17 mm	12.54 mm	12.54 mm	16.42 mm	16.42 mm
<b>Dynamic performance</b>						
Tracking error	0.14 ms	0.14 ms	0.16 ms	0.14 ms	0.30 ms	0.24 ms
<b>Step response time</b> (settling to 1/1000 of full scale)						
1 % of full scale	0.25 ms	0.30 ms	0.40 ms	0.35 ms	0.65 ms	0.50 ms
10% of full scale	0.70 ms	0.70 ms	1.2 ms	1.2 ms	1.6 ms	1.4 ms
<b>Typical speeds<sup>(1)</sup></b>						
Marking speed	2.5 m/s	2.5 m/s	2.0 m/s	2.5 m/s	1.0 m/s	1.5 m/s
Positioning speed	15.0 m/s	15.0 m/s	10.0 m/s	15.0 m/s	7.0 m/s	12.0 m/s
<b>Writing speed<sup>(2)</sup></b>						
good writing quality	900 cps	900 cps	640 cps	800 cps	410 cps	460 cps
high writing quality	600 cps	600 cps	400 cps	500 cps	280 cps	320 cps
<b>Weight</b> (without objective)	650 g	1 kg	1.9 kg	1.9 kg	2.3 kg	2.3 kg

<sup>(1)</sup> with F-Theta objective, f = 160 mm

<sup>(2)</sup> single-stroke characters of 1 mm height

## Common Specifications

(all angles are in optical degrees)

### Dynamic performance

Repeatability	< 22 µrad
Offset drift	30 µrad/K
Gain drift	80 ppm/K
Long-term drift over 8 hours	< 0.3 mrad plus temperature-induced gain and offset drift

### Optical performance

Typical scan angle	±0.35 rad
Gain error	< 5 mrad
Zero offset	< 5 mrad
Nonlinearity	< 3.5 mrad

### Power requirements

±15 V DC,  
max. 3 A each  
(SCANcube<sup>®</sup> 7 max. 2 A)

### Interface

Analog version (SCANcube <sup>®</sup> )	±4,8 V
Digital version	XY2-100 <sup>(3)</sup> or SL2-100

### Operating temperature

25 °C ± 10 °C

<sup>(3)</sup> intellicube<sup>®</sup> XY2-100 Enhanced,  
SCANcube<sup>®</sup> XY2-100 Standard

