

high performance meets high power



hurrySCAN® 20, hurrySCAN® 25, hurrySCAN® 30

These scan heads are designed to quickly and precisely deflect and position laser beams with powers up to the kilowatt range. With apertures of 20, 25 and 30 mm, small spot sizes are achieved along with large image fields.

Stable operating conditions and high long-term stability are provided by water cooling of the entrance aperture, electronics and galvanometer scanners, supplemented by air cooling of the deflection mirrors. This also ensures reliable operation with applications requiring high laser powers.

The compact housing is dustproof and water spray resistant. Attachment provisions at the water-cooled beam entrance and at the beam exit ease installation of add-on components such as focusing lenses and cross jets. The hurrySCAN® 20, hurrySCAN® 25 and hurrySCAN® 30 are inter-compatible and can be controlled via SCANLAB's RTC® interface boards.

The high quality of SCANLAB's scan heads is the result of years of experience in the development and manufacture of galvanometer scanners and scan systems. In addition, every scan system must first pass the SCANcheck burn-in test before it is released for shipment to the customer.

Typical Fields of Application:

- **Laser materials processing:** welding, cutting, drilling, texturing, marking, hardening, deep engraving, microstructuring
- **Processing of organic materials** such as paper, textiles, foils, leather
- **Rapid prototyping, rapid tooling**
- **3D applications**
- **Processing-on-the-fly**



hurrySCAN® 20 hurrySCAN® 25 hurrySCAN® 30

Optics

Galvanometer mirrors and objectives with optimized mounts are available for all typical laser types and working fields.

To optimally utilize standard objectives, the hurrySCAN® 25's two scan axes have differing maximum scan angles. This results in an elliptical image field with the larger semi-axis perpendicular to the entrance beam axis.

Attachment Provisions

Threaded and non-threaded holes at the housing's beam entrance side facilitate mounting of the scan head and installation of fiber optic outputs.

On the beam exit side, threaded holes are available for attaching add-on components such as cross jets, illumination, distance sensors or thermal shields.

Options

- A varioSCAN or varioSCAN 40_{FLEX} can extend the hurrySCAN® scan heads into 3D scan systems.

- These scan heads can be equipped with an additional reference sensor system for automatic self-calibration to obtain extremely high long-term stability.
- hurrySCAN® 20 and hurrySCAN® 30 can be equipped with high-performance light-weight mirrors.
- All scan heads can be supplemented via a camera adapter for process monitoring.

Common Specifications

(all angles are in optical degrees)

Dynamic Performance

Repeatability < 22 µrad
Long-term drift over 8 hours < 0.6 mrad (after warm-up)

Optical Performance

Gain error < 5 mrad
Zero offset < 5 mrad
Skew < 1.5 mrad
Nonlinearity < 3.5 mrad

Power Requirements ±(15+1.5) V DC, max. 6 A each

Input Signals

Analog version alternatively:
±4.8 V; ±9.6 V;
±4.8 mA; ±9.6 mA
Digital version XY2-100 standard⁽⁴⁾

Output Signals 3 status signals per axis

Analog version TTL level
Digital version XY2-100 standard⁽⁴⁾

Weight (without objective) approx. 5.8 kg

Operating Temperature 25 °C ± 10 °C

Typical Air Requirements clean, filtered air 20 l/min at Δp < 2 bar

Typical Water Requirements 5 l/min at Δp < 0.1 bar, p < 4 bar

Water Requirements Δp < 0.1 bar, p < 4 bar

⁽⁴⁾ alternatively: SL2-100 or optical data transfer

Product-Dependent Specifications (all angles are in optical degrees)

	hurrySCAN® 20	hurrySCAN® 25	hurrySCAN® 30
Aperture (dimension a)	20 mm	25 mm	30 mm
Beam displacement (dimension b)	25.25 mm	29.88 mm	35.53 mm
Dimension c	67.25 mm	72.00 mm	72.00 mm
Optical Performance			
Typical scan angle of scanner 1	±0.35 rad	±0.26 rad	±0.35 rad
Typical scan angle of scanner 2	±0.35 rad	±0.40 rad	±0.35 rad
Typical field size – ellipse ^{(1), (2)}	-	80 mm x 130 mm	-
Typical field size – square ^{(1), (2)}	90 mm x 90 mm	75 mm x 75 mm	50 mm x 50 mm
Dynamic Performance			
Tracking error	0.35 ms	0.50 ms	0.55 ms
Step Response Time (settling to 1/1000 of full scale)			
1% of full scale	0.8 ms	0.9 ms	1.2 ms
10% of full scale	2.5 ms	3.2 ms	4.5 ms
Typical Speeds ⁽¹⁾			
Marking speed	1.0 m/s	0.8 m/s	0.7 m/s
Positioning speed	6.0 m/s	5.0 m/s	3.0 m/s
Writing speed ⁽³⁾			
good writing quality	320 cps	260 cps	220 cps
high writing quality	210 cps	170 cps	150 cps

⁽¹⁾ with F-Theta objective, f = 163 mm ⁽²⁾ limited by vignetting at objective ⁽³⁾ single-stroke characters of 1 mm height

Legend

- 1 Beam in
- 2 Mounting screws (M6 threads)^(#)
- 3 Flange^(#)
- 4 Alignment pins (6_{h6})^(#)
- 5 Objective
- 6 Beam out
- 7 Wider construction (drawn dashed) only for hurrySCAN® 30
- E Electrical connectors
- A Connection for cooling air
- W Connections for cooling water

^(#) not included

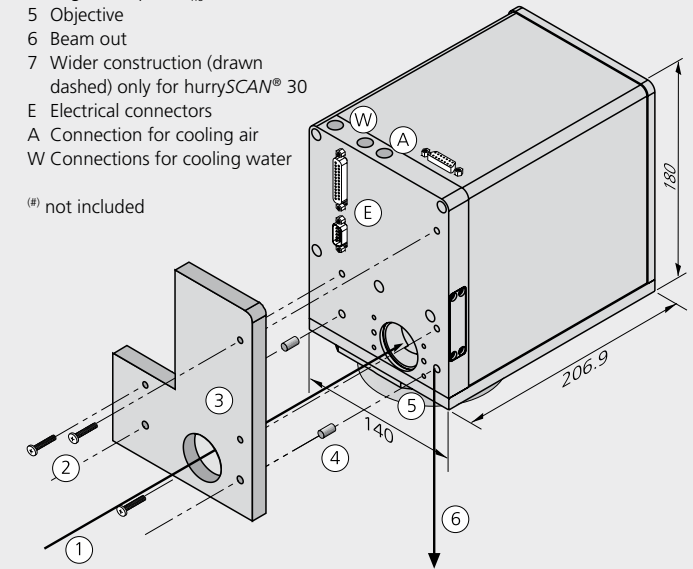

Beam exit side with beam displacement

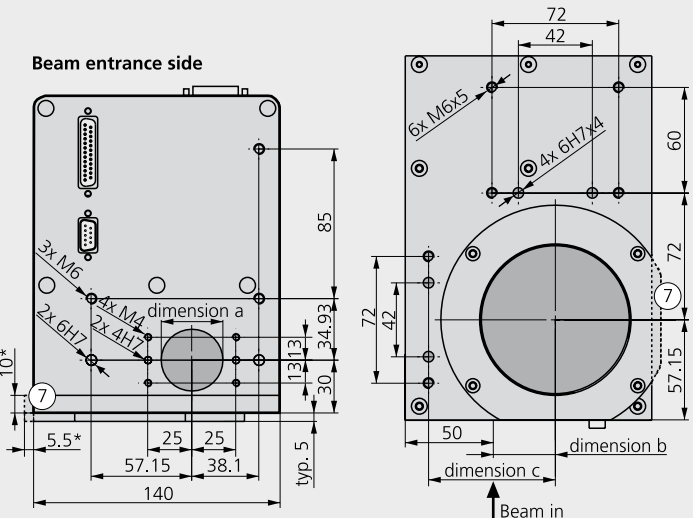

*Dimensions only relevant for the hurrySCAN® 30

All dimensions in mm



SCANLAB AG · Siemensstr. 2a · 82178 Puchheim · Germany
Tel. +49 (89) 800 746-0 · Fax +49 (89) 800 746-199 · info@scanlab.de · www.scanlab.de

SCANLAB America, Inc. · 100 Illinois Street · Suite 200 · St. Charles, IL 60174 · USA
Tel. +1 (630) 797-2044 · Fax +1 (630) 797-2001 · info@scanlab-america.com · www.scanlab-america.com