

new dimensions – optics in motion



varioSCAN, varioSCAN 40_{FLEX}

varioSCAN dynamic focusing devices enable the laser focus to be moved quickly and precisely along the optical axis. This is achieved via an optical element driven by a high-performance, tilt-free linear motor.

In XY scan systems, the varioSCAN can replace costly flat field objectives. The varioSCAN is an exceptionally ideal solution in applications for which standard flat field objectives are unavailable. The varioSCAN can also extend XY scan systems into 3D beam deflection systems. The laser focus is guided along the contour of the workpiece being processed, thus enabling processing in three dimensions. The varioSCAN_{FLEX} additionally allows continuously adjusting the image field size, working distance and spot size.

Controlling both an XY scan unit and the varioSCAN is easily achieved via SCANLAB's RTC® interface boards.

SCANLAB offers optical configurations for a wide variety of working distances, image field sizes, beam diameters, wavelengths and laser powers. The varioSCAN 40's integrated air and water cooling ensure operation at very high laser powers. The varioSCAN 20 can be optionally equipped with a water-cooled entrance aperture.

Typical Fields of Application:

- Drilling, cutting, welding
- Laser deep engraving
- Rapid prototyping, rapid tooling
- Microstructuring
- 3D workpiece processing



varioSCAN 20 / 40, varioSCAN 40_{FLEX}

How It Works

During the scanning process, a diverging optic in the varioSCAN is positioned with high dynamics along the optical axis with respect to a stationary focusing optic. This produces a change in the system's overall focal length, synchronized with the mirror motion. The varioSCAN focusing unit can thereby expand XY scan systems with up to 33 mm apertures into 3-axis scan systems easily controlled by an RTC® interface board.

The focusing optic of the varioSCAN 40_{FLEX} is motor-driven, enabling continuously variable image field sizes and working distances. The varioSCAN 40_{FLEX}'s housing contains all optical components and the electronics.

Optics

SCANLAB offers a variety of optical configurations for optimally tuning the system to the customer's particular application. Thus, a maximum image field size is achieved with the minimum spot size. The varioSCAN 40 allows the customer to self-install various exchangeable optics sets.

Common Specifications

Electrical Connections (with SSV30)	
Power Requirements ±(15+1.5) V DC, max. 1.5 A each	
Input Signals	
Analog version	alternatively: ±4.8 V; ±9.6 V; ±4.8 mA; ±9.6 mA
Digital version	XY2-100 standard or optical data transfer
Only for varioSCAN 40 _{FLEX} : Step motor inputs	
Output Signals	
Analog version	3 status signals TTL level
Digital version	XY2-100 standard or optical data transfer
Only for varioSCAN 40 _{FLEX} : Limit-switch signals	
Weight of SSV30 amplifier board 190 g	
Operating Temperature 25 °C ± 10 °C	
Installation Position horizontal	

Type-Dependent Specifications (all angles are in optical degrees)

	varioSCAN 20	varioSCAN 40 / 40 _{FLEX}
Beam Input Aperture	up to max. 8 mm	up to max. 16 mm
Output Aperture	up to max. 20 mm	up to max. 40 mm
Dynamic Performance		
Tracking error	1.0 ms	1.4 ms
Typical processing speed ⁽¹⁾	8 rad/s	5 rad/s
Typical positioning speed ⁽¹⁾	18 rad/s	9 rad/s
Weight (depending on optical configuration)	500 g to 700 g	approx. 2.4 kg / 4.5 kg

⁽¹⁾ with XY scan system

Typical 3-axis scan system optical configurations

	varioSCAN 20		varioSCAN 40		varioSCAN 40 _{FLEX}	
Laser	Nd:YAG x 3	Nd:YAG x 2	Nd:YAG	Diode	CO ₂	CO ₂
Wavelength	355 nm	532 nm	1064 nm	800 nm - 1000 nm	10.6 μm	10.6 μm
XY Scan Unit	10 mm aperture	14 mm aperture	20 mm aperture	25 mm aperture	30 mm aperture	30 mm aperture
Flat Field Objective	without	with f = 100 mm	with f = 163 mm	without	without	without
Image Field Size	(600 x 600) mm ²	(50 x 50) mm ²	(90 x 90) mm ²	(200 x 100) mm ²	(200 x 200) mm ² to (600 x 600) mm ²	(600 x 600) mm ² to (2000 x 2000) mm ²
Focus Range in Z Direction	± 20 mm	± 2.5 mm	± 5 mm	± 5 mm	±2 mm to ±40 mm	±2 mm to ±400 mm
Focus Diameter (1/e²)	110 μm (M ² =1.3)	10 μm (M ² =1.3)	80 μm (M ² =5)	320 μm (M ² =20)	200 μm (M ² =1) to 550 μm (M ² =1)	550 μm (M ² =1) to 1.8 mm (M ² =1)
Beam Expansion Factor	3.8	4.1	2.8	2.95	2.4 to 2.1	2.1 to 1.9
Focal Length varioSCAN	(1350 ± 60) mm	-	-	(495 ± 20) mm	(395 ± 18) mm to (940 ± 140) mm	(940 ± 60) mm to (2850 ± 600) mm
Max. Laser Power cw	25 W	60 W	500 W	500 W	500 W	500 W



SCANLAB AG · Siemensstr. 2a · 82178 Puchheim · Germany
Tel. +49 (89) 800 746-0 · Fax +49 (89) 800 746-199 · info@scanlab.de · www.scanlab.de

SCANLAB America, Inc. · 100 Illinois Street · Suite 200 · St. Charles, IL 60174 · USA
Tel. +1 (630) 797-2044 · Fax +1 (630) 797-2001 · info@scanlab-america.com · www.scanlab-america.com

Legend

- 1 Water-cooled aperture (optional for varioSCAN 20)
- 2 Linear motor with diverging optic
- 3 Clamping surface
- 4 Objective adapter
- 5 Focusing optic (motor-driven for varioSCAN 40_{FLEX})
- 6 Focusing ring
- 7 Deflection mirrors
- A Connection for cooling air
- W Connections for cooling water

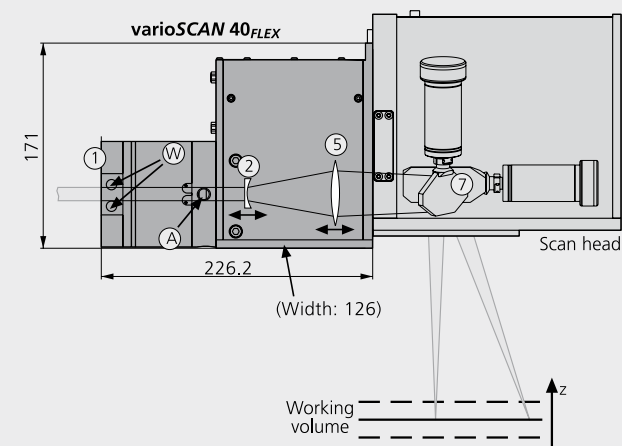
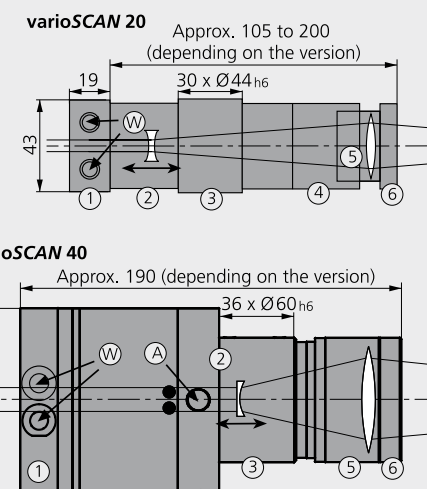

All dimensions in mm

