



vision for scan heads

The **camera adapter** enables camera-based observation of a galvanometer scan head's working field. Typical applications include process monitoring or determination of a workpiece's orientation during laser processing.

The camera adapter ensures easy integration into new as well as existing systems. The adapter's mechanical interfaces enable straightforward mounting between the scan head and laser flange. The system allows 4 alternative orientations of the objective with camera. To facilitate monitoring of work surfaces, light arriving from the workpiece is decoupled via the adapter's beam splitter and direc-

ted through the camera's objective onto its imaging chip. The laser beam on the other hand passes practically unattenuated through the beam splitter to the scan system. Optical configurations are available for various wavelengths. Customers can freely select a camera suitable for their requirements and attach it via a C-mount.

The camera adapter is specifically designed for maximum observation field size and its integrated iris diaphragm can be adjusted for optimal imaging quality. In addition, color or interference filters can be installed.

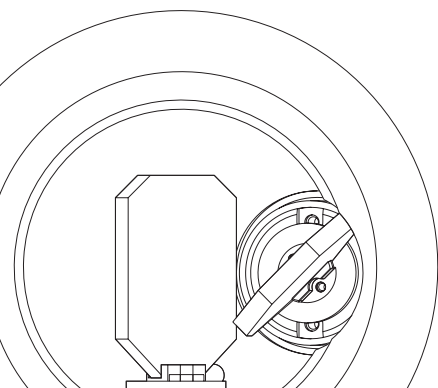

Camera Adapter

Installation

The camera adapter is mounted between the scan head's beam entrance and the laser flange (see drawing). The bore holes at the camera adapter's beam entrance and exit side are compatible with the mounting holes of the scan heads from SCANLAB. The beam splitter housing can be adjusted so that the camera and objective unit are oriented either up, down or sideways (see drawing).

Principle of Operation

The camera adapter enables camera-based observation of a scan head's working field. Therefore, a dichroitic beam splitter inside the beam splitter housing decouples light

reflected from the illuminated workpiece and arriving the scan head's beam entrance via the scan objective and the scan mirrors. The light is decoupled from the beam path and then directed to the camera. The laser beam on the other hand passes through the beam splitter practically unattenuated.

The decoupled light is directed through the camera objective onto the active imaging surface of the camera (e.g. CCD chip). Threaded in the beam splitter housing, the objective unit contains the camera objective, an iris diaphragm and provisions at the beam entrance side for mounting a color filter. Camera image sharpness is achieved by manually adjusting the objective unit's focus ring.

Customers can select an illumination wavelength compatible with the optical specifications of the beam splitter, scan mirrors and other system optics.

Observation Field and Resolution

The size of the observation field depends on the focal lengths of the scan objective and camera objective and on the camera chip's size. A scan objective focal length of 163 mm typically produces a camera image field size of approx. 7.5 mm x 10 mm and a maximum optical resolution of around 10 µm (see table). This can be further increased by a 2-fold or 4-fold camera attachment, depending on the pixel resolution of the camera.

Typical Optical Configurations with Scan Head

Laser wavelength	1064 nm	532 nm	355 nm	266 nm
Observation wavelength	880 nm	635 nm	635 nm	635 nm
Scan head aperture	14 mm	10 mm	10 mm	10 mm
Scan head mirror coating⁽¹⁾	1064 nm + 880 nm	532 nm + 635 nm	355 nm + 635 nm	266 nm + 635 nm
Flat field objective	163 mm	160 mm	100 mm	103 mm
Processing field size	110 x 110 mm ²	110 x 110 mm ²	50 x 50 mm ²	50 x 50 mm ²
Beam splitter				
Laser wavelength	1030 nm - 1110 nm	488 nm - 532 nm	343 nm - 355 nm	257 nm - 266 nm
Range for observation wavelength ⁽¹⁾	450 nm - 900 nm	615 nm - 900 nm	510 nm - 680 nm	630 nm - 670 nm
Focal length camera objective	105 mm	105 mm	105 mm	105 mm
Camera chip size	1/2"	1/2"	1/2"	1/2"
Interference filter	880 nm	635 nm	635 nm	635 nm
Observation field size	approx. 7.5 x 10 mm ²	approx. 7 x 9.5 mm ²	approx. 5 x 6.5 mm ²	approx. 5 x 6.5 mm ²
Max. optical resolution	approx. 10 µm	approx. 15 µm	approx. 10 µm	approx. 10 µm

⁽¹⁾ observation only in the wavelength range reflected by the scan mirrors

Common Specifications

Diameter of entering beam	max. 30 mm ⁽²⁾
Camera	
Connection type	C-Mount
Maximum chip size	2/3"
Weight (without camera)	approx. 1.6 kg
Operating temperature	25 °C ± 10 °C

⁽²⁾ depending on the scan head

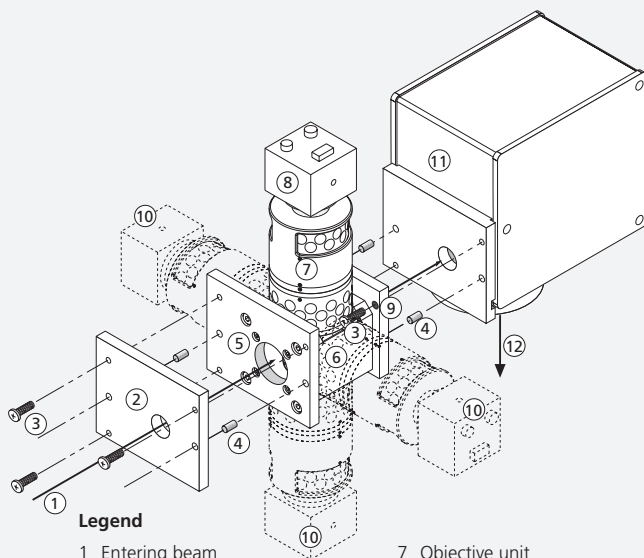

Legend

- | | | |
|-------------------------------------|--|---|
| 1 Entering beam | 7 Objective unit | 13 C-mount extension (optional) ^(c) |
| 2 Laser flange ^(a) | 8 Camera ^(a) | 14 Focus ring ^(a) not included |
| 3 Mounting screws ^(a) | 9 Beam-exit side camera adapter ^(b) | 15 Camera objective ^(b) for SCANcube and intellicube scan heads, the camera adapter is equipped with a special adapter plate at its beam-exit side |
| 4 Alignment pins ^(a) | 10 Alternative orientation | 16 Iris diaphragm ^(a) |
| 5 Beam-entrance side camera adapter | 11 Scan head ^(a) | 17 Color filter ^(a) |
| 6 Beam splitter housing | 12 Emerging beam | 18 Beam splitter ^(c) depending on the respective configuration, can additionally contain a 2-fold or 4-fold camera attachment for enlarging the resolution |

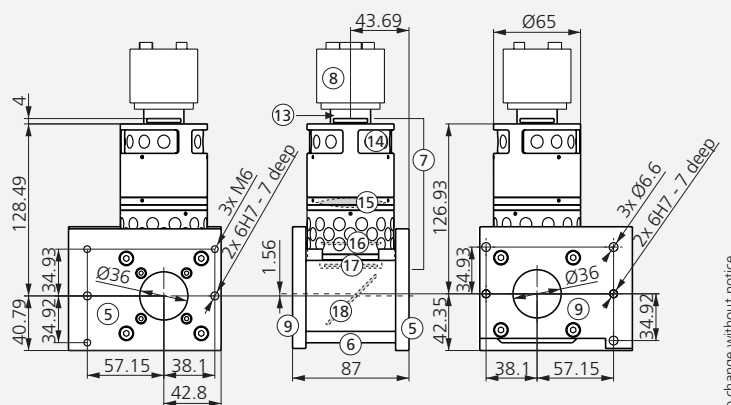

all dimensions in mm

02/2021 Information is subject to change without notice. Product photos are non-binding and may show customized features.